

# Thermoelectric water meter energy harvesting

**C A Gould**

Staffordshire University, Stoke-on-Trent, Staffordshire, ST4 2DE, United Kingdom

C.A.Gould@staffs.ac.uk

**Abstract** Domestic electronic water meters are installed by water meter utility companies to accurately measure household water usage for billing purposes, progressing from simple electromechanical systems to state-of-the art volumetric electronic smart meters with RF radio transmission, remote reading, and automatic billing capability. The motivation for this work is to replace, or increase the lifetime of, the on-board lithium-ion battery installed in electronic water meters with a thermoelectric energy harvesting solution to create a business advantage. Practical field experiments at several different water meter installations in the UK, USA, and Australia have demonstrated a temperature difference can exist between the top-side and bottom-side of a water meter, and between several different areas of the meter and the surrounding air. This temperature difference can be harnessed to generate electrical power using thermoelectricity. A prototype thermoelectric water meter energy harvesting system has been designed, and experiments demonstrate the system will operate when a temperature difference is present across the thermoelectric module, giving an output voltage of 3.7V to power the water meter electronics directly or to provide a charge current for the existing lithium-ion battery to increase its lifetime. The work concludes it is feasible, although still challenging, to develop a solution for a novel thermoelectric powered water meter. Further work is required to address the commercial challenges that exist, develop and optimise the prototype solution into a production ready prototype, and conduct further tests using a standard UK domestic water profile at a UK water meter test site.

## 1. Introduction

Residential or domestic water meters are installed by water meter utility companies to accurately measure household water usage for billing purposes, and it has become increasingly common for water meters to be compulsory for residential users. In the past the UK, like many other countries, did not directly measure domestic household water usage. A fixed yearly charge was levied by utility companies independent of water consumption. The UK has moved over time to direct water metering and billing for domestic water use, and now all new-build houses will typically have a water meter fitted and households are billed for measured water usage rather than a standing charge. Over time, the majority of UK households will eventually use a domestic water meter for measurement and billing purposes [1]. There are a variety of different types of domestic water meters, ranging from relatively simple electromechanical systems, to state-of-the art volumetric electronic smart meters with RF radio transmission, remote reading, and automatic billing capability [2-3].

The motivation for this work is to replace, or increase the lifetime of, the on-board lithium-ion battery installed in electronic water meters with a thermoelectric energy harvesting system. An electronic water meter will typically use an internal 3.6V lithium-ion battery, which has a quoted operational lifetime of 10 years [3]. Removing this 3.6V battery from the water meter or increasing the batteries lifetime beyond

10 years creates a business advantage. A literature search into self-powered water meters or water meter energy harvesting highlights some published work in this area, often using an in-line water turbine to harness water flow to generate electrical power using magnetic effects, the exploitation of vibration using piezoelectricity, and limited work into the use of temperature difference via thermoelectricity, however, commercially available electronic and smart water meters are still reliant on the use of internal batteries as a power source rather than use of energy harvesting technologies [4-9].

The objective of this work is to identify the feasibility of rapidly introducing thermoelectric power generation energy harvesting techniques to commercially available residential electronic water meters. Analysis of a sample of residential electronic water meter power requirements highlights in normal operation, without any radio transmission, an electronic water meter draws a supply current of around  $12\mu\text{A}$ . For meters with RF transmission capability, a one-way  $25\text{mW}$  radio transmission function draws  $46\text{mA}$  when transmitting, and between  $20\mu\text{A}$  to  $25\mu\text{A}$  when not transmitting. Similarly, for water meters that incorporate a two-way radio transmission, the radio transmits once per day at  $50\text{mA}$ , receives a read request once per day at  $18\text{mA}$ , and has a radio seek function which causes an  $18\text{mA}$  peak current for  $1\text{mS}$  each second. The meter draws between  $20\mu\text{A}$  to  $25\mu\text{A}$  when not transmitting. It is feasible for an electronic water meter without radio transmission to be continuously powered using a thermoelectric energy harvesting system as the current drawn is relatively low. However, for meters which incorporate a one-way, and in particular, a two-way radio frequency transmission, the thermoelectric energy harvesting system may be best suited to provide a charge current to the existing on-board lithium-ion  $3.6\text{V}$  battery, extending the lifetime of the battery, rather than to remove and directly replace the battery.

## **2. Background thermoelectric and energy harvesting theory**

Thermoelectricity utilizes naturally occurring or man-made temperature gradients and temperature differences to generate electrical power. Unfortunately, the amount of useful power generated is often very low and in the milli-watt (mW) to watt (W) range, and this has been a barrier to widespread commercial application. Parallel advances in energy storage using electric double layer capacitors, often referred to as supercapacitors, and low power boost and DC to DC converters has enabled practical thermoelectric energy harvesting systems to be realized and become commercially viable [10]. This section provides the main theoretical background into thermoelectric power generation and energy harvesting systems necessary to apply this technique to electronic water meter applications.

### *2.1. Thermoelectric power generation*

A single thermoelectric module can generate a small amount of electrical power if a temperature difference is maintained between two sides of the module. Normally, one side of the module is attached to a heat source and is referred to as the ‘hot’ side or  $T_H$ , the other side of the module is attached to a heat sink and is called the ‘cold’ side or  $T_C$ . The heat sink is used to create and maintain a temperature difference between the hot and cold sides of the module. If a resistive load  $R_L$  is connected across the module’s output terminals, electrical power will be generated at the load when a temperature difference exists between the hot and cold sides of the module due to the Seebeck effect [10]. A schematic diagram of a thermoelectric module, operating as a thermoelectric power generator, is shown in figure 1.

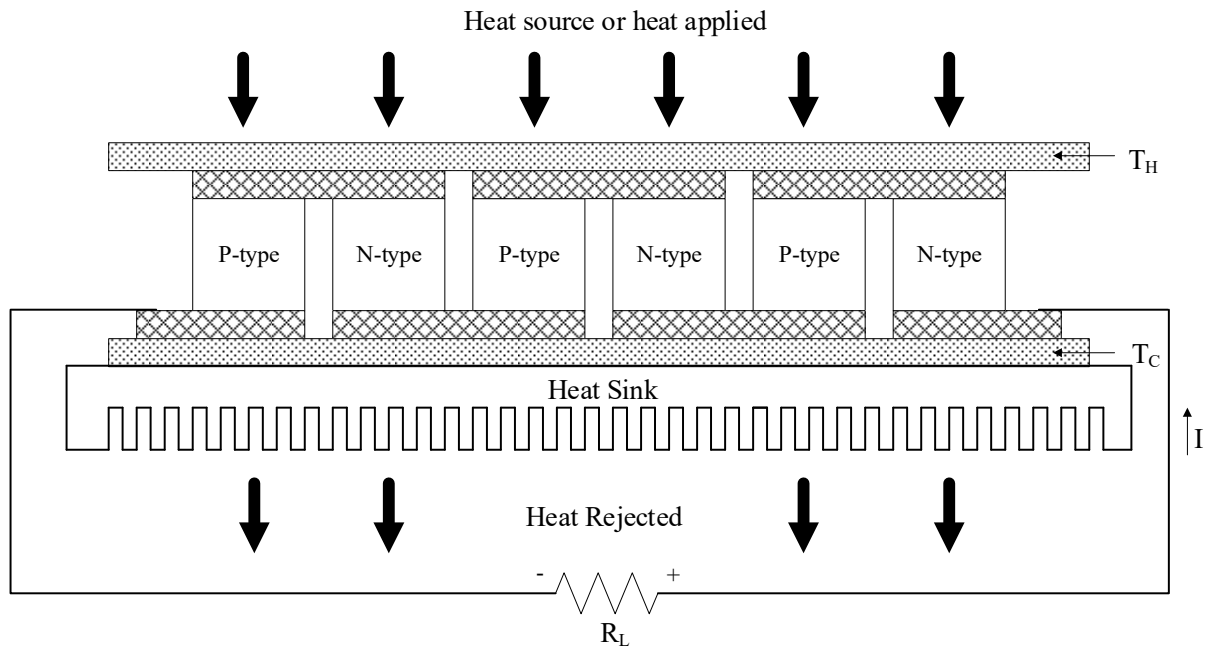

**Figure 1.** A thermoelectric module configured to operate as a thermoelectric generator [10].

Thermoelectric modules contain several individual thermoelectric couples connected together electrically in series and thermally in parallel, and these couples are constructed from two ‘pellets’ of semiconductor material usually made from Bismuth Telluride ( $\text{Bi}_2\text{Te}_3$ ), as this material has been found to show the most pronounced thermoelectric effects around room temperature. One of these pellets is doped with acceptor impurity to create a P-type pellet, the other is doped with donor impurity to produce an N-type pellet. The two pellets are physically linked together on one side, usually with a small strip of copper, and mounted between two ceramic outer plates that provide electrical isolation and structural integrity. If a temperature difference is maintained between two sides of a thermoelectric couple, thermal energy will move through the p-type and n-type pellets, and because these pellets are electrically conductive, charge carriers are transported by this heat. This movement of heat and charge carriers creates an electrical voltage called the Seebeck voltage. A single thermoelectric couple is generally of limited practical use, as the rate of useful power generated due to the Seebeck effect is very small. Practical thermoelectric modules are constructed with several of these thermoelectric couples connected electrically in series and thermally in parallel, with modules typically containing a minimum of three thermoelectric couples, rising to one hundred and twenty-seven couples for larger devices [10].

## 2.2. Thermoelectric energy harvesting

Thermoelectric power generation systems have typically needed to have a very high temperature gradient across the thermoelectric module(s) in order to achieve a useful electrical power output. This limitation has been a barrier to the successful application of this technology for power generation, and limited the technologies use to mainly niche applications. However, with parallel developments in the area of electrical energy storage in supercapacitors, and low power DC to DC converters and boost converters, thermoelectric energy harvesting systems can now operate from very low temperature gradients of around  $1^\circ\text{C}$  and be able to output useful power levels. This was previously very difficult to achieve and would have required several thermoelectric modules to be connected electrically in series, increasing the overall system weight, size, and cost, and would only achieve relatively small levels of power generation unless a significant temperature gradient could be maintained across the modules.

The thermoelectric output voltage generated by a thermoelectric module can be boosted to a useful and stable level by using a low power boost converter and DC to DC converter. If the electrical power output from the converter is then accumulated and stored for future use in a supercapacitor, it is possible to increase the potential output current of the system. A simplified block diagram of a thermoelectric energy harvesting system is shown in figure 2, highlighting the six main stages, with the energy stored in the supercapacitor accumulated over time and released to the load when required.

Similar to other energy harvesting technologies, the duty cycle of the electrical load is a critical factor in determining the design of a thermoelectric energy harvesting system, as the output power of a single thermoelectric module is often too low to power other electrical and electronic components directly unless a significant temperature difference or gradient is available, or several thermoelectric modules are connected together electrically in series. The use of temporary electrical storage in supercapacitors leads to a focus on the duty cycle of the load, as it is necessary to ensure the capacitor can be recharged before the load becomes active to ensure repeatable and reliable operation [10-11].



Figure 2. Simplified thermoelectric energy harvesting block diagram [10-11].

2.3. Low power boost converter and DC to DC converter

The electrical power generated by a thermoelectric module can be boosted to a useful level by using a DC energy harvesting circuit, shown in figure 3, based around a Linear Technology LTC3108 step-up DC to DC converter. The LTC3108 uses a boost converter, in the form of an external 1:100 step-up transformer, an internal MOSFET and associated circuitry within the converter to increase the voltage from the thermoelectric module. The frequency of oscillation is determined by the inductance of the transformer secondary winding and is typically in the range of 10kHz to 100kHz. The AC voltage that is developed on the secondary winding of the transformer is boosted and rectified using the internal rectifiers within the converter and an external charge pump capacitor C1 of 1nF. The converter itself is powered from the input voltage supplied by the thermoelectric module, and the output of the converter, which is configurable, has been set to 3.7V. The converter operates at very low input voltages of 20mV, which can be achieved when a 1°C or higher temperature difference exists between the ‘hot’ and ‘cold’ sides of the thermoelectric module [12].

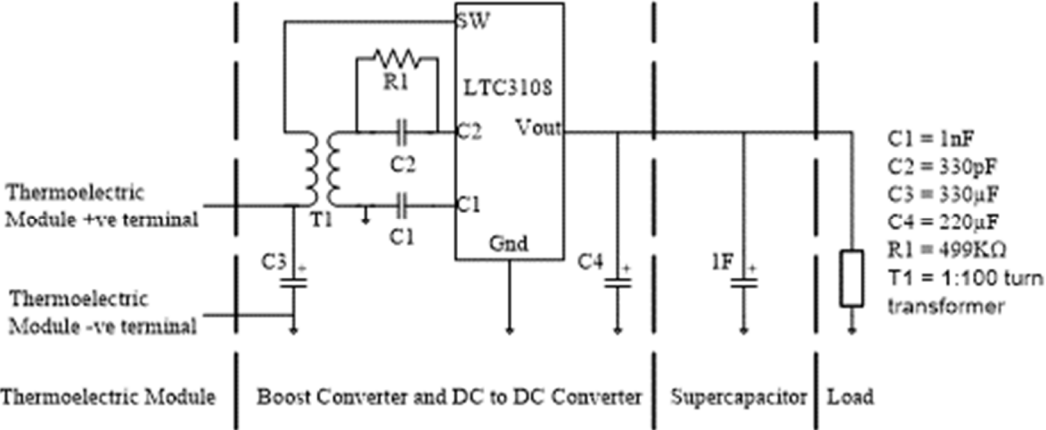
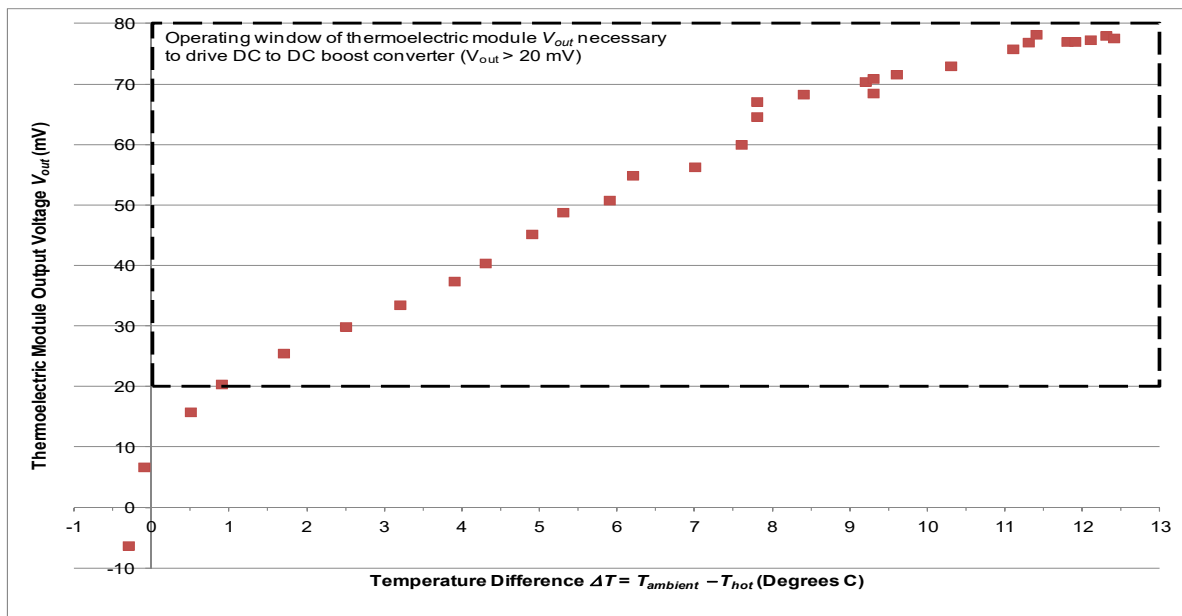

Figure 3. Thermoelectric energy harvesting circuit [10-11].

#### 2.4. Practical test results – Thermoelectric energy harvesting system

For practical test purposes, a medium sized 71-couple 30mm x 30mm x 3.8mm thermoelectric module has been mounted in-between a heat source and a heat sink, with the hot side of the module  $T_h$  attached to the heat source and the cold side of the module  $T_c$  attached to a small heat sink measuring 60mm x 60mm x 16mm. The heat source can be set to lower the temperature of the hot side of the module below ambient temperature in  $1^\circ\text{C}$  steps, creating a negative temperature gradient between the hot and cold sides of the thermoelectric module, as the cold side of the thermoelectric module and heat sink assembly is approximately maintained at ambient temperature. The use of a negative temperature gradient is due to the findings of field experiments at water meter installations in the UK, USA, and Australia, which demonstrated a negative temperature difference below ambient conditions can exist at different areas of the water meter when water is passing through the meter during the flow measurement process and is discussed further in section 3. The thermoelectric module output terminals are connected to the input of the low power boost converter and DC to DC converter and needs to output in excess of 20mV for the converter to operate, which is achieved when the temperature gradient across the module is greater than  $1^\circ\text{C}$ , and the dashed-line box in figure 4 highlights the region where the thermoelectric module output voltage is sufficient to drive the converter. Similarly, figure 5 demonstrates that with a temperature difference across the module of greater than  $1^\circ\text{C}$ , the converter outputs a capacitor charge voltage  $V_{chrg}$  of 3.7V, and a capacitor charge current  $I_{chrg}$  starting at  $15\mu\text{A}$ , rising to around  $200\mu\text{A}$  as the temperature difference across the module increases. It should be noted the capacitor charge current is not only dependent on the temperature gradient across the module but also on the state-of-charge of the capacitor.



**Figure 4.** Thermoelectric module output voltage  $V_{out}$  with a temperature difference  $\Delta T$  of between  $0^\circ\text{C}$  to  $13^\circ\text{C}$  below ambient of  $22^\circ\text{C}$  using a 71-couple 30mm x 30mm x 3.8mm thermoelectric module.

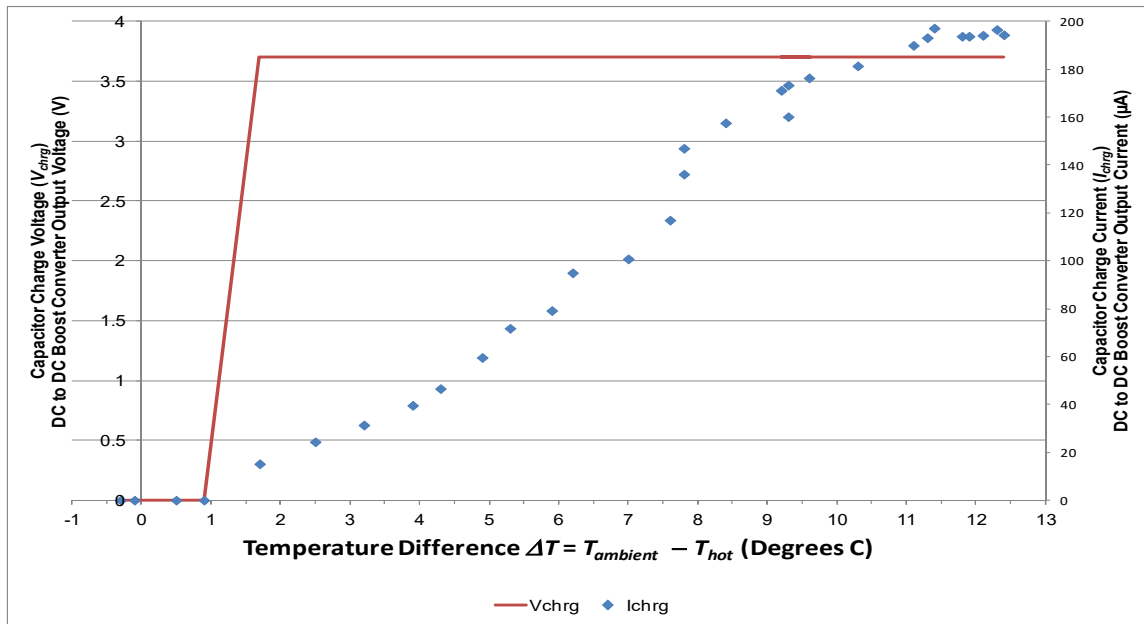

**Figure 5.** The capacitor charge voltage and current (DC to DC boost converter output voltage and current)  $V_{chrg}$  and  $I_{chrg}$  with a temperature difference  $\Delta T$  of between  $0^{\circ}\text{C}$  to  $13^{\circ}\text{C}$  below ambient of  $22^{\circ}\text{C}$  using a 71-couple  $30\text{mm} \times 30\text{mm} \times 3.8\text{mm}$  thermoelectric module.

### 3. Application of thermoelectric energy harvesting to electronic water meters

The principle of thermoelectric energy harvesting, described in section 2, has been applied to an Elster V200 series volumetric electronic water meter. This type of water meter represents the forefront of electronic smart meters, with optional RF radio transmission, remote reading, and automatic billing capability, and is often installed in UK water meter installations [3].

#### 3.1. Design concept

Temperature measurement experiments conducted at water meter installations in the UK, USA, and Australia has identified a negative temperature difference can exist between the top-side and bottom-side of the water meter. The most likely cause of this temperature difference is the lower temperature of the flowing water in the bottom-side of the meter, as the top-side of the meter is isolated from this water, and water only flows through the bottom of the meter during the water flow measurement process, therefore no flowing water comes into direct contact with the inside of the top-part of the meter, as shown in figure 6. In practical meter installations, it is necessary for the top-side of the meter to be able to freely rotate 360 degrees to maintain the ability to visually read the meter display from any desired angle, therefore the most practical area to mount the thermoelectric module is on the bottom-side of the water meter, shown in figure 7. In this configuration, if the temperature difference between the bottom-side of the water meter, and therefore the hot side of the thermoelectric module  $T_h$ , and the cold side of the module  $T_c$  mounted onto a heatsink is greater than  $1^{\circ}\text{C}$  the thermoelectric module will generate a closed-circuit output voltage in excess of 20mV. The thermoelectric module generator output terminals are connected to the converter PCB, which can be located inside the water meter housing along with the other electronic meter circuitry. When the output voltage of the thermoelectric module is greater than 20mV, the boost converter and DC to DC converter increases the output voltage to 3.7V with a charge current of around  $15\mu\text{A}$ , up to a maximum of 4.5mA with higher levels of temperature gradient present across the thermoelectric module/water meter. The maximum output current limit of 4.5mA is determined by the LTC3108 converter design. The output power from the converter could be used to power the water meter electronics directly if the current output is sufficient, or to charge a supercapacitor

which, once fully charged, can supply 3.7V at the required load current to the water meter electronics, removing the existing 3.6V lithium-ion battery or to provide a charge current to the battery to increase lifetime. The overall solution is shown as a system block diagram in figure 8.

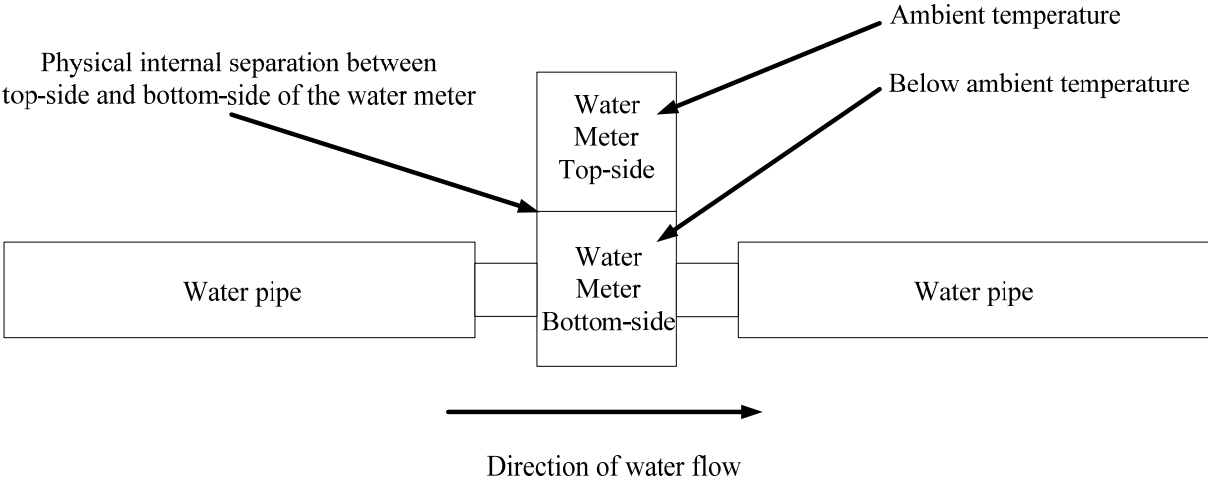

**Figure 6.** Temperature difference exists between top-side and bottom-side of water meter due to the lower temperature of the water flowing through only the bottom section of the water meter.

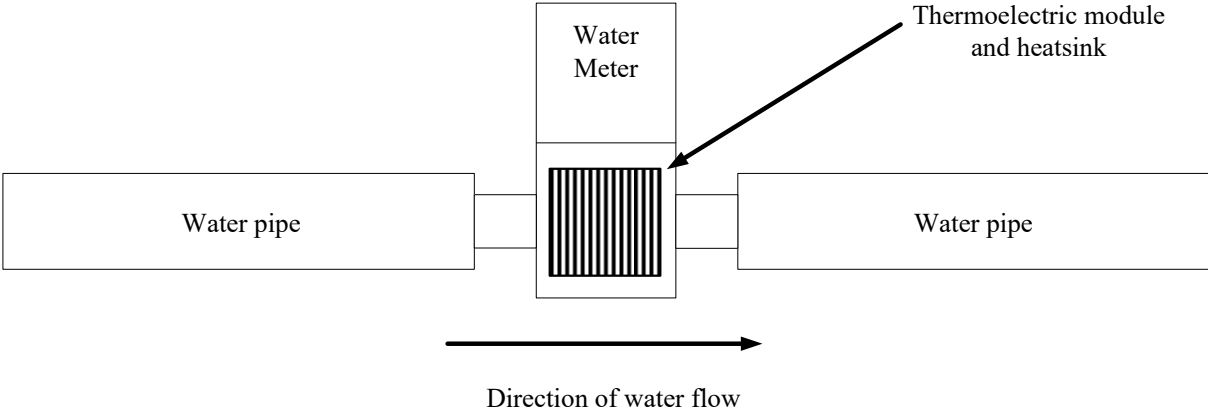

**Figure 7.** Thermoelectric module and heatsink mounted onto bottom-side of the water meter.

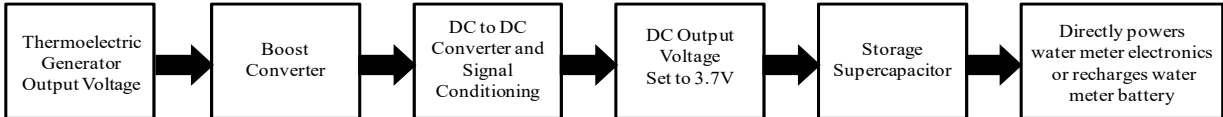

**Figure 8.** Water meter thermoelectric energy harvesting system block diagram.

### 3.2. Practical test results – Thermoelectric water meter energy harvesting prototype

A medium sized 71-couple 30mm x 30mm x 3.8mm thermoelectric module has been connected as shown in figure 7, with the hot side  $T_h$  of the thermoelectric module mounted onto the bottom-side of the water meter, and the cold side  $T_c$  of the module attached to a small heat sink measuring 60mm x 60mm x 16mm. A Grant TX150 scientific water bath/pump with controllable water temperature has been attached to the water meter inlet and outlet connections to enable the circulating water temperature through the meter to be varied and controlled. The water bath/pump temperature has been varied from ambient conditions of around 25°C to 5°C in 1°C steps every 5 minutes, with the temperature of the thermoelectric module  $T_h$  and  $T_c$ , ambient temperature, capacitor charge voltage  $V_{chg}$  and charge current  $I_{chg}$  measured as shown in figure 9 and figure 10 respectively. Figure 9 highlights the temperature gradient across the thermoelectric module increases as the water temperature passing through the water meter decreases. This is as expected, as the hot side of the thermoelectric module  $T_h$  is in direct contact with the outer casing of the water meter. When the temperature of the water has reached 17°C, approximately 8°C below ambient conditions, the boost and DC to DC converter begins to operate, indicated by the dashed-line box in figure 9, and the converter outputs an open circuit voltage of 3.7V. Figure 10 demonstrates the converter output when connected to a 1F storage supercapacitor, highlighting a capacitor charge voltage of 3.7V and charge current starting from approximately 2 $\mu$ A rising to 40 $\mu$ A as the temperature of the circulating water through the water meter decreases, increasing the temperature gradient across the thermoelectric module. It should be noted the capacitor charge current is not only dependent on the temperature gradient across the module but also on the state-of-charge of the capacitor.

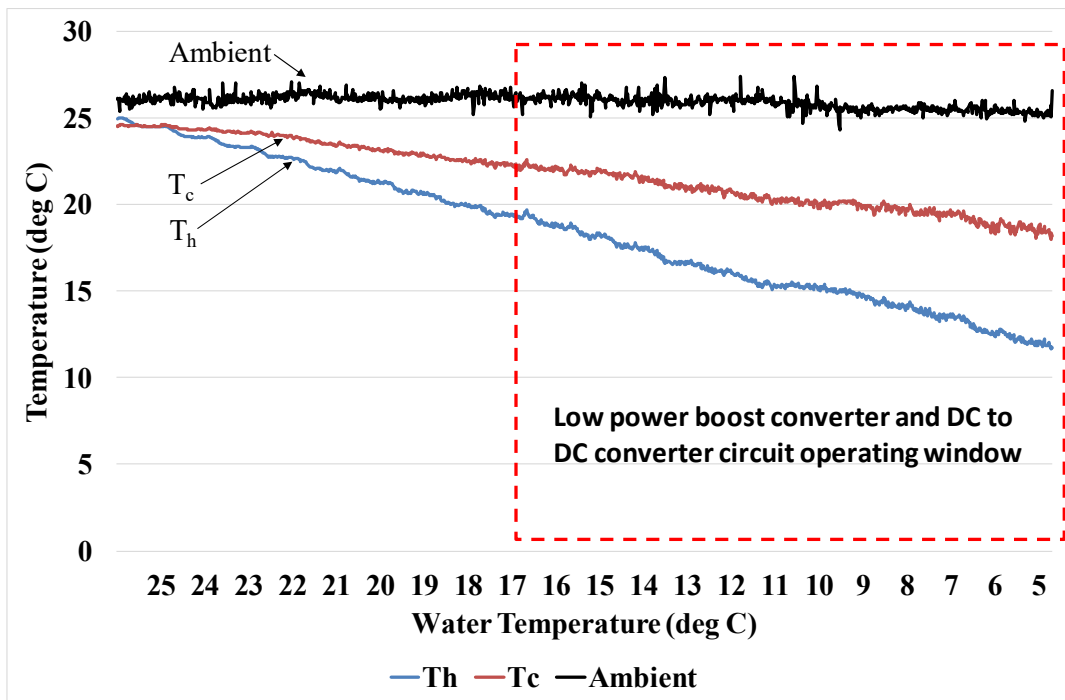

**Figure 9.** Temperature of the hot and cold sides of the thermoelectric module when the circulating water temperature through the water meter is varied from 25°C to 5°C in 1°C steps every 5 minutes.



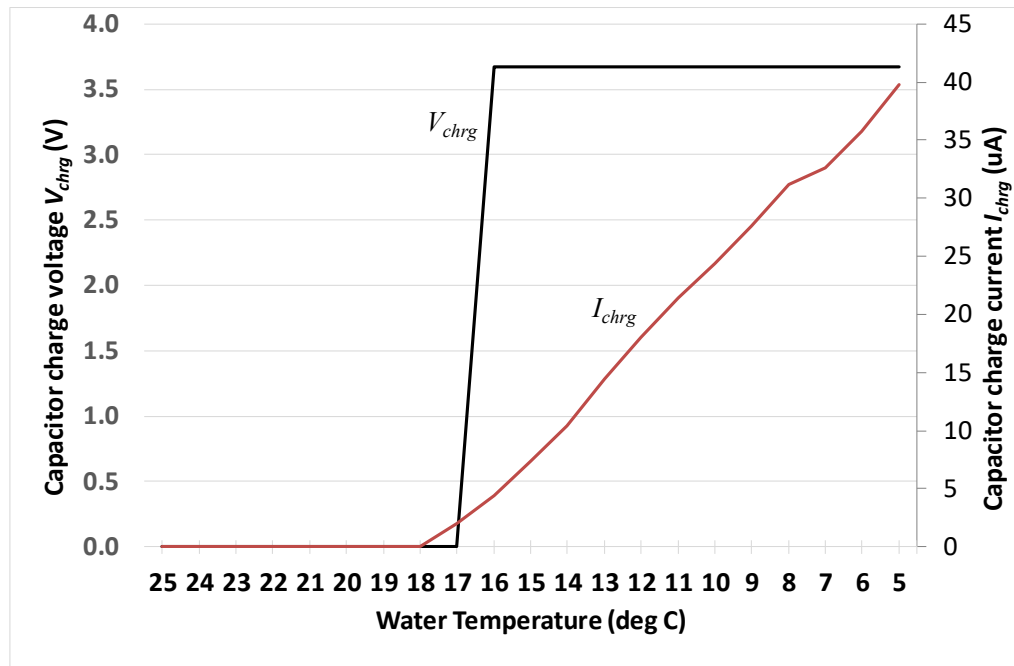

**Figure 10.** DC to DC converter output and 1F supercapacitor charge voltage  $V_{chrg}$  and charge current  $I_{chrg}$  when the circulating water temperature through the water meter is varied from 25°C to 5°C in 1°C steps every 5 minutes.

#### 4. Discussion

The motivation for this work is to replace, or increase the lifetime of, the on-board lithium-ion battery installed in electronic water meters with a thermoelectric energy harvesting solution to create a business advantage. Analysis of the power requirements of electronic water meters highlights the power consumption of the RF radio transmission as a critical factor. Electronic water meters without any radio transmission draw only a small amount of current, and it is feasible for the thermoelectric energy harvesting system to directly power this type of meter. For meters with RF transmission capability, a one-way, and in particular a two-way radio transmission function is technically challenging, the thermoelectric energy harvesting system is best suited to provide a charge current to the existing on-board lithium-ion 3.6V battery, extending the lifetime of the battery rather than direct replacement.

It has been established that a temperature difference can exist between the top-side and bottom-side of a water meter, and between several different areas of the water meter and the surrounding ambient air, most likely caused by the temperature of the flowing water passing through the water meter. A prototype water meter thermoelectric energy harvesting system has been designed, with a single 71-couple thermoelectric module and heatsink mounted onto the bottom-side of the water meter. The output terminals of the thermoelectric module are connected to a low power boost and DC to DC converter and storage supercapacitor. It has been demonstrated that a temperature difference of greater than 2.9°C across the thermoelectric module, which occurs with a flowing water temperature through the water meter of 8°C below ambient temperature, enables the DC to DC converter output to become active and output a voltage of 3.7V and a capacitor charge current of 2μA, rising to 40μA with higher levels of temperature difference present across the thermoelectric module/water meter. The electrical power generated by the system can be used to provide a charge current to the existing water meter 3.6V lithium-ion battery to increase its lifetime in meters equipped with RF radio transmission, or potentially, to remove the existing 3.6V battery entirely in electronic water meters without radio transmission. Overall, it is feasible to develop a thermoelectric powered electronic water meter, although several commercial

and technical factors need to be further developed and addressed. Further work is required to optimize the prototype into a production ready prototype, reduce costs, practically demonstrate the thermoelectric water meter energy harvesting system directly powering the water meter electronics or the on-board battery, and conduct further validation tests using a standard UK domestic water profile at a UK water meter installation.

## 5. Conclusions

Electronic water meters are installed by water meter utility companies to accurately measure household water usage for billing purposes, with the motivation of this work to replace, or increase the lifetime of, the on-board lithium-ion battery using a thermoelectric energy harvesting solution. Practical field experiments at different water meter installations in the UK, USA, and Australia has demonstrated a temperature difference can exist between the top-side and bottom-side of a water meter, and between several different areas of the meter and the surrounding air which can be harnessed to generate electrical power using thermoelectricity. A prototype thermoelectric water meter energy harvesting system has been designed, and experiments demonstrate the system will operate when a temperature difference greater than 2.9°C is present across the thermoelectric module, giving an output voltage of 3.7V to power the water meter electronics directly or to provide a charge current to the existing lithium-ion battery to increase its lifetime. The work concludes it is feasible, although still challenging, to develop a solution for a novel thermoelectric powered water meter, acknowledging that several commercial factors need to be addressed. Further work is required to develop and optimize the prototype solution into a production ready prototype, reduce costs, and conduct further tests using a standard UK domestic water profile at a UK water meter installation.

## Acknowledgments

This work was funded by the UK Technology Strategy Board (TSB) project number 113185 with collaborating companies Elster Metering Ltd and Staffordshire University UK in August 2013 to August 2015

## References

- [1] Ofwat 2019 *Metering* [Online] Available at <https://www.ofwat.gov.uk/households/your-water-bill/metering/#switchwm> [accessed 27th September 2019]
- [2] Honeywell International Inc. 2017 *V100 range of domestic volumetric cold water meters* Lit Ref: 8516D1257
- [3] Honeywell International Inc. 2019 *V200 & V210 Hybrid Product Specification Rev 2* Lit Ref: 8519B22119
- [4] Becker P, Folkmer B, Goepfert R, Hoffmann D, Willmann A and Manoli Y 2013 Energy Autonomous Wireless Water Meter with Integrated Turbine Driven Energy Harvester *J. Phys.: Conf. Ser.* **476** 012046
- [5] Tasic V, Staake T, Stiefmeier T, Tiefenbeck V, Fleisch E and Tröster G, 2012 Self-powered water meter for direct feedback *Proc. 3rd IEEE Int. Conf. on the Internet of Things* 24-26 Oct. 2012 (Wuxi, China) pp. 24-30. doi: 10.1109/IOT.2012.6402300
- [6] Xue L & Chong, P H J 2019 Design and Implementation of a Self-Powered Smart Water Meter *Sensors* **19** 4177. 10.3390/s19194177
- [7] Gabrielli L, Pizzichini M, Spinsante S, Squartini S and Gavazzi R 2014 Smart water grids for smart cities: A sustainable prototype demonstrator *Proc. 2014 European Conference on Networks and Communications* 23-26 June 2014 (Bologna, Italy) pp. 1-5. doi: 10.1109/EuCNC.2014.6882685
- [8] Di Zenobio D, Steenhaut K, Celidonio M, Sergio E and Verbelen Y 2012 A self-powered wireless sensor for water/gas metering systems *Proc. IEEE Int. Conf. on Communications* 10-15 June 2012 (Ottawa, Canada) pp. 5772-5776. doi: 10.1109/ICC.2012.6364711
- [9] Squartini S, Gabrielli L, Mencarelli M, Pizzichini M, Spinsante S and Piazza F 2013 Wireless M-

Bus sensor nodes in smart water grids: The energy issue *Proc. 4th Inter. Conf. on Intelligent Control and Information Processing* 9-11 June 2013 (Beijing, China) pp. 614-619. doi: 10.1109/ICICIP.2013.6568148

- [10] Gould C 2019 Thermoelectric Energy Harvesting *A Guide to Small-Scale Energy Harvesting Techniques* Ed. Manyala R *IntechOpen* doi: 10.5772/intechopen.85670
- [11] Gould C A, Shamma N Y A, Grainger S and Taylor I 2011 Thermoelectric Power Generation – Properties, Application and novel TCAD Simulation *Proc. 14th IEEE European Conf. Power Electronics and Applications* 30th August to 1st September 2011 (Birmingham, UK) pp. 1-10
- [12] Linear Technology Corporation 2010 *LTC3108 Product Datasheet* Lit Ref: LT0410 Revision A